

SIGMA @ Mohawk College
Mathematics and Statistics Competition

Grade 10

General Interest

- How many litres of gas may be contained in a spherical balloon with a surface area of 1687 dm²?
Answer: 6515 L
- The speed of sound in water is 1460m/s.
 - How far will the sound travel in 12.5 s in water? Provide the answer in kilometres (round to the nearest integer) **Answer: 18 250 m = 18.25 km = 18 km**
 - How long will the sound travel across Ontario Lake that is 310.6 km long? Provide the answer in minutes (round to the nearest integer) **Answer: 212.7 s = 3.5 min = 4 min.**

Mechanical Engineering

- The figure shown is a part as it is location dimensioned on an engineering drawing before programming for CNC. All dimensions are in cm. The hole locations (x and y coordinates) are to be programmed using the tool positioning (coordinate) system.

Adapted from Mathematics for Machine Technology by Robert D. Smith

- Determine the hole locations (coordinates) of points A – G. The origin is indicated at one corner of the plate;

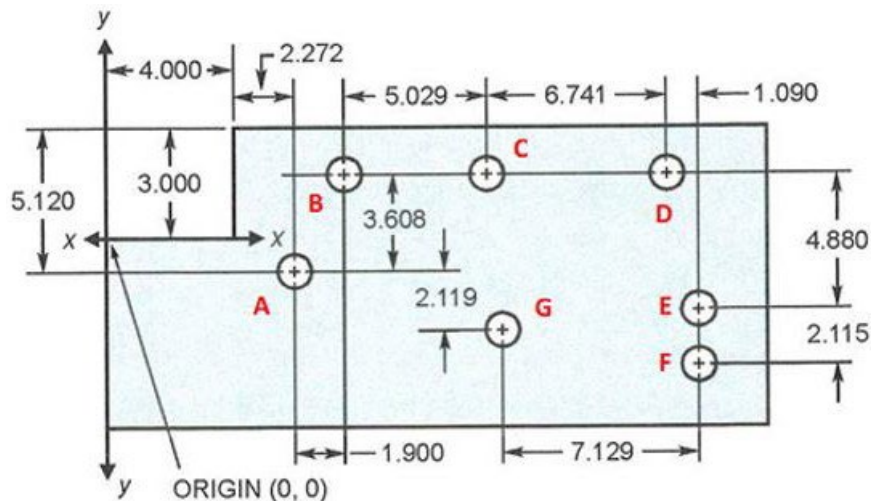

**Answer: A (6.272, -2.120); B (8.172,1.900); C (13.201,5.029); D (19.942,1.488);
E (21.032, -3.392); F (21.032, -5.507); G (13.903, -4.239)**

- b) Determine the hole locations (coordinates) of points A - F in respect to the origin (0, 0) at the centre of the bored hole.

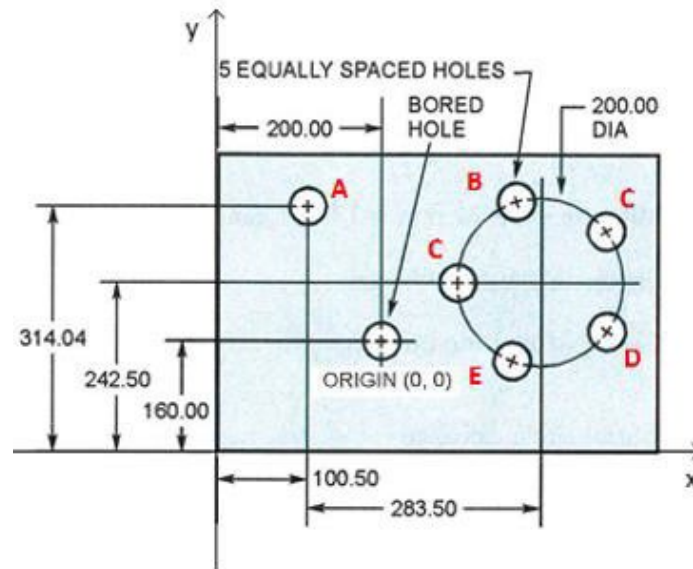

Answer: A (-99.50,154.04); B (153.10,177.61); C (264.90,141.28); D (264.90,23.72);
 E (153.10, -12.61); F (84.00,82.50)

4. Justin and Selena are investigating the stretching properties of a spring. Their experiment consists of stretching a spring and recording the mass and the length for each attempt. The following table presents the data they recorded:

Mass (in grams)	10	20	30	40
Length of stretch (in cm)	2	4	6	8

- a) Graph the data (Mass on the x-axis and Length on the y-axis).

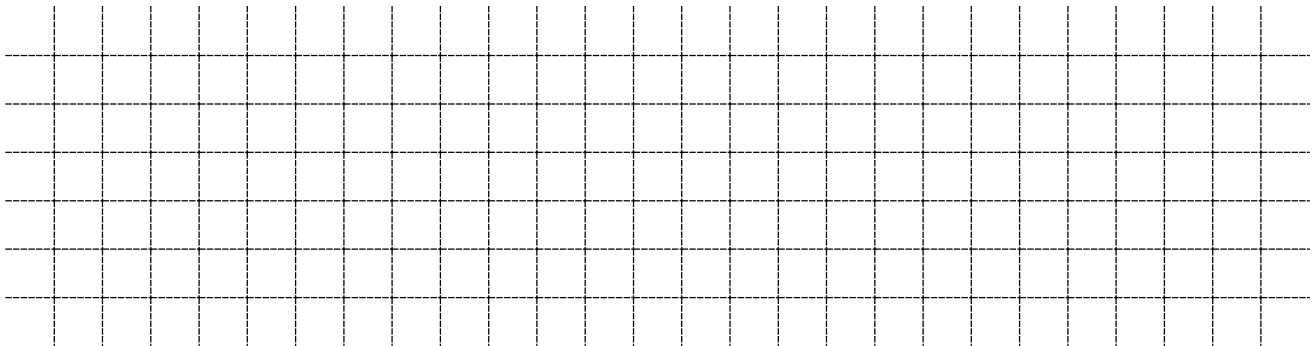

- b) Use the graph to determine how far the spring would stretch if a mass of 50 g was attached?
 c) Use the graph to determine the mass attached if the spring was stretched 5 cm.
 d) Determine the equation of the line graphed in (a).
 (hint: $y = mx + b$ where m is the slope expressed as rise/run)
 e) Determine the mass attached if the spring was stretched 10.4 cm.
 f) Determine how far the spring would stretch if a mass of 175 g was attached.

Answers: b) 10 cm; c) 0.5 g; d) 52; e) 35 cm

5. A storage tank 44 cm long has a regular hexagonal front and back panel with dimensions as shown below:

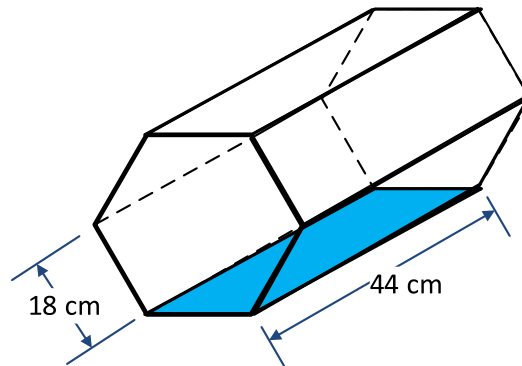

- Determine the area of the flat rectangular bottom (represented in blue).
- Determine the surface area of the tank
- Determine the area of hexagonal front panel.
- Determine the volume of liquid that the tank can hold

Answers: a) 792 cm^2 ; b) 864 cm^2 ; c) $38\,016 \text{ cm}^3$; d) 4752 cm^2

Industrial Engineering

6. There are many different types of welding, as Tungsten Inert, or Metal Arc Welding, or oxy acetylene gas welding with different charge. The price of welding, K (in \$) of every metre steel sheet of thickness d (in mm) can be approximated with the formulas:
 $K = 1.5 + 0.95d$ using welding type A and $K = 4 + 0.6d$ using welding type B.
 Determine the thickness of the metal sheet after which Type B welding will become cheaper than Type A welding. **Answer: approximately after 7.15 cm**

Civil Engineering

- A new pavement is planned for the west side of Mohawk College parking lot. The work was estimated to be completed by 32 workers for 12 days. However, the supervisor was able to hire 16 more workers. For how many days will the planned paving be completed? **Answer: 8 days**
- Considering heat loss in a building the building code states that the window area in a building cannot exceed 20% of the total floor area. The new building has a floor area of 175 square metres and the plan suggests 45 square metres of windows. Will this satisfy the building code? **Answer: No, the maximum allowed window area is 35 m^2**
- A company is contracted to dig a 60 m long trench with 45 cm wide and 1.2 m deep and install a metal pipe of 18 cm in diameter. The pipe will take up the entire length of the trench. Determine how many cubic metres of extra material is needed to backfill the trench. (Round your answer to the nearest cubic metre) (Unit conversions $1 \text{ m}^3 = 100^3 \text{ cm}^3$) **Answer: 31 m^2**
- Determine how many cubic metres of concrete are required for a 32 m long sidewalk, 25 dm wide and 80 mm deep. If the cost of concrete is \$170 per cubic metre, determine the cost of the concrete used. **Answer: 6.4 m^2 ; \$1088**

Architecture

11. Spaceship Earth at Epcot Centre in Florida has the form of a sphere with a diameter of 50.2 metres.



Digital image, Walt Disney World Resort - Spaceship Earth,
< [https://en.wikipedia.org/wiki/Spaceship_Earth_\(Epcot\)](https://en.wikipedia.org/wiki/Spaceship_Earth_(Epcot))>

- Determine the surface area of Spaceship Earth.
- Determine the volume of Spaceship Earth.
- This year the design engineer is considering building an additional sphere to represent the Moon. The volume of this new sphere needs to be 27% of the volume of existing Spaceship Earth sphere.

Determine the Surface Area of the new sphere that will represent Spaceship Moon.

Answers:

12. Architects often use the golden spiral, which is based on the Fibonacci sequence, to design visually appealing structures. The golden spiral is created by drawing quarter-circle arcs inside squares with side lengths that follow Fibonacci numbers.

An architect is designing a decorative window based on the golden spiral. The first square in the design has a side length of 5 cm, the second square has a side length of 8 cm, and the third square has a side length of 13 cm. If the pattern continues following the Fibonacci sequence, what will be the total perimeter of the first five squares in the design?

Answers:

Biotechnology

13. An examination of a parasite egg in a lab specimen shows it to be 38 units long in a microscopic field. If each unit is 27.3 micrometres long, determine the real-life length of the egg. (Provide the answer to the nearest hundredth of a millimetre)

Unit conversion: 1 millimetre = 1000 micrometres) **Answer: 1.04 mm**

14. A technician is asked to grow a certain kind of bacteria in a container. The growth medium for the bacteria requires 12 g of glucose per litre. The medium was prepared by adding 108 grams of glucose to 20 litres. Is the medium required prepared correctly?

Answer: No, the prepared medium is 5.4 g per litre.

15. An examination of a parasite egg in a lab specimen shows it to be 38 units long in a microscopic field. If each unit is 27.3 micrometres long, determine the real-life length of the egg. (Provide the answer to the nearest hundredth of a millimetre)

Unit conversion: 1 millimetre = 1000 micrometres) **Answer: 1.04 mm**

Chemical Engineering

16. The temperature outside is measured to be 102° F. Given that the Fahrenheit and Celsius are linked by the equation: $C = \frac{5}{9}(F - 32^{\circ})$ and Celsius and Kelvin are linked by the equation: $K = C + 273^{\circ}$, calculate the outside temperature in Kelvin.
(Round your answer to the nearest integer) **Answer: 312° K**

Computer Science

17. Data storage is measured in bytes. A kilobyte is 1024 bytes. A megabyte is 1024 kilobytes. A gigabyte is 1024 megabytes. Exactly how many bytes of storage are there on a 16-gigabyte memory stick? **Answer: 17 179 869 184**

Electrical Engineering

18. The electrical code states how to calculate the net load in watts for different types of appliances and lights. As the general lighting and small appliances do not require electricity on a constant basis in order to calculate their net load, we need to add 100% of the first 3000 Watts to the 35% of the remainder.
Determine the net load if the total load for general lighting and small appliances is 8000 watts.
Answer: 4750 Watts

Transportation

19. To transport next shipment of oil, the Gas Oil Company needs 36 trucks each holding 16.5 tonnes oil. However, the company decided to use their new self-driving trucks that hold 24.75 tonnes. How many of these new self-driving trucks will need to be used. **Answer: 24 trucks**
20. 140 farm animals needed to be transferred by boat. The cost was estimated to be \$0.92/kg weight per day and the average weight of one animal was 350 lb. The total journey is planned to be 18 days. Determine the total cost (in dollars) of the transport (round your answer to the nearest cent) (Unit conversion 1kg = 2.2 lb). **Answer: \$368,836.36**
21. By the manufacturer's standards the low beam light on an automobile is positioned such that the beam drops 85 cm for every 42 m in front of the car.
Determine the angle between the beam and the road?
(Round your answer to the nearest tenth of a degree) **Answer: 1.2°**
22. A new ski lift is opened at the nearby ski centre. The total distance that is connected by the lift is 3380 m and the angle between the lift and the horizontal plane is $18^{\circ}0'26''$. Determine the height of the hill that is connected by the new ski lift.
(Round your answer to the nearest metre) **Answer: 1045 m**
23. To transport next shipment of oil, the Gas Oil Company needs 36 trucks each holding 16.5 tonnes oil. However, the company decided to use their new self-driving trucks that hold 24.75 tonnes. How many of these new self-driving trucks will need to be used. **Answer: 24 trucks**

Nursing Practice

24. As a nurse, part of Izaak's daily duties is to mix medications in the proper proportions for his patients. For one of his regular patients, he always mixes Medication A with Medication B in the same proportion. Last week, his patient's doctor indicated that he should mix 50 milligrams of Medication A with 15 milligrams of Medication B. This week, however, the doctor said to only use 9 milligrams of Medication B. How many milligrams of Medication A should be mixed this week?

Grade 11

General Interest

- A ball is dropped from a height of 12 metres. Each time it strikes the ground, it bounces up to 80% of the previous height.
 - What is the height the ball bounces up to after it strikes the ground for the fifth time?
Answer: 3.9 m
 - How many times does the ball need to strike the ground before its bounce is less than 0.2 metres? **Answer: 19**
 - What total distance does the ball travel before it stops bouncing? Round the answers to the nearest tenth of a metre where applicable. **Answer: 108.0 m**
- A bank is investigating a case of credit card fraud. The security team interviews five employees who had access to customer data. They know that exactly two employees are lying, while the other three are telling the truth. Here's what they said:
Alex: "Jamie is responsible for the fraud."
Jamie: "Taylor is innocent."
Taylor: "The person who committed the fraud has a name with exactly 6 letters."
Jordan: "The fraudster's name starts with 'J'."
Morgan: "The guilty person is lying."
Based on the information given and knowing that exactly two people are lying, who is responsible for the fraud? (*HINT: Identify which statements are consistent with only two people lying.*)
- Jorge is considering buying one of two new bathroom scales. He's weighing himself several times on each scale to see which one provides the most reliable readings.
 - Scale A gives an average weight of 165 pounds with a standard deviation of 3.1 pounds.
 - Scale B gives an average weight of 165 pounds with a standard deviation of 1.9 pounds.Which scale should Jorge buy, and why? (**Answer: Scale B that has a smaller standard deviation if he wants a scale that gives him more consistent and reliable results.**)
- Tony and Alice are both high school teachers grading assignments for their students. Tony corrected 10 papers from his class and found that the average grade for his group was 70. Alice corrected the remaining 20 papers from her class and found that the average grade for her group was 80.
What is the overall average grade for all the students in the class? (**Answer: 76.67%**)

Industrial Engineering

- Gear A has 30 teeth and makes 80 rotations per minute. How many teeth has Gear B (attached to gear A) that makes 60 rotations per minute? **Answer: 40 teeth**

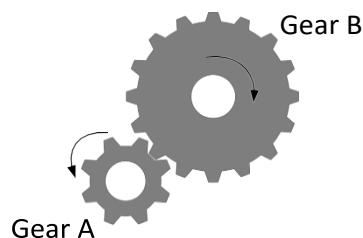

6. A quality control inspector is inspecting a panel of transistors for its quality. The results are given in the table below. One transistor is chosen at random.

Manufacturer	Acceptable Quality	Unacceptable Quality
A	156	44
B	234	16
C	119	121
D	891	19

Determine the probability for each of a) to c).

- a) The transistor is from manufacturer A with acceptable quality; **Answer: 9.75%**
 b) The transistor is from manufacturer B given that it is acceptable; **Answer 16.71%**
 c) The transistor is not acceptable given that it is from manufacturer C; **Answer 50.42%**

Civil Engineering

7. Mr. Peralta can take one of three routes to work. Each route has a different probability being blocked: $P(\text{route A}) = 28\%$; $P(\text{route B}) = 10\%$; $P(\text{route C}) = 35\%$. Determine the probability Mr. Peralta can get to work? **Answer: 99.02%**
8. A biologist is asked to determine the growth rate of a certain type of bacteria. He is given one hundred bacteria in a favorable growth medium. After 8 hours the biologist counts 850 bacteria. Assuming exponential growth, determine the growth constant "k" for the bacteria?
 (Hint: use $A = Ce^{kt}$) **Answer: 0.2675**
9. A certain type of bacteria growing in a container doubles every 8 minutes. A biologist started with 1 bacterium and assuming the container has the favourable growth medium how many bacteria could be present at the end of one hour? (Hint: use $A = Ce^{kt}$) **Answer: 65**
10. In mixing a weed-killing chemical, a 45% solution of the chemical is mixed with an 85% solution to get 20 L of a 60% solution. Determine how much of each solution is needed? **Answer: 12.5 L of the 45% solution and 7.5 L of the 85% solution**

Chemical Engineering

11. A relationship between the rate of a reaction k (constant) and the temperature T (in Kelvins) is given by the formula: $k = A \times e^{-\frac{E_A}{RT}}$
 where A is a frequency factor (constant), and the exponential part of the equation measures the fraction E_A (in $Jmol^{-1}$) is the activation energy, and R (in $JK^{-1}mol^{-1}$) is the gas constant. For a certain reaction the activation energy is $E_A = 52.0 k Jmol^{-1}$, the gas constant n $R = 8.31JK^{-1}mol^{-1}$ and $A = 1.00$.
- a) Determine the rate of the reaction when the temperature $T = 20^\circ C$.
- b) You plan to increase the temperature to $40^\circ C$. Determine how much faster the reaction would be at $40^\circ C$ than at $20^\circ C$. (Round your answer to the nearest integer)
- Unit Conversions: $K = C + 273^\circ$
Answer: a) 5.3×10^{-10} , b) 4 times faster

12. How many millilitres of 20% alcohol solution should be added to 40mL of a 50% alcohol solution to prepare a 30% alcohol solution? **Answer: 80 mL of 20% alcohol solution should be added.**
13. How many millilitres of pure water should be added to 100 mL of 30% saline solution in order to make a 10% saline solution? **Answer: 200 mL of pure water should be added.**
14. How many litres of pure antifreeze should be added to 12 litres of 10% antifreeze solution to prepare 80% antifreeze solution? **Answer: 42 L of pure antifreeze should be added.**

Electrical Engineering

15. An electrical resistor is rated at 500 ohms plus or minus 3%. Determine the range of resistance. **Answer: 485 ohms to 515 ohms**
16. A box of 100 semiconductor chips contains 30 chips that are defective. We select at random, without replacement, from the box.
 - a) Determine is the probability that the first one selected is defective.
 - b) Determine the probability that the first defective is the 5th one chosen.
 - c) Determine the probability that the second one selected is defective given that the first one was defective.
 - d) Determine the probability that the first 2 chosen are defective.
 - e) Determine the probability the first 5 selected are defective.
 - f) How does the answer to parts (a) - (e) change if chips selected were replaced prior to the next selection?**Answer: a) 30%; b) 7.3%; c) 29%; d) 8.8%; e) 0.19%; f) (a) same; (b) 7.2%; (c) 30% (d) 9% (e) 0.24%**
17. Two voltage phasors are shown below:

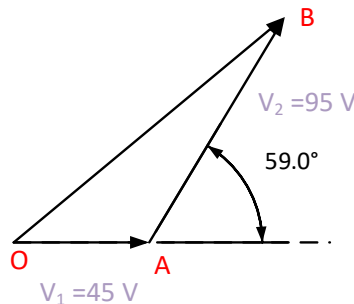

The first phasor has a magnitude of $V_1 = 45\text{V}$ (i.e. length of OA) and the second of $V_2 = 95\text{V}$ (i.e. length of AB).

- a) Determine the value of their resultant (i.e. length OB). **Answer: 124 V**
- b) Determine the angle the resultant makes with V_1 (i.e. $\sphericalangle AOB$) **Answer: 41°**

Computer Science

18. Determine how many 2-digit numbers can be formed using digits 0 – 9. **Answer: 90**
19. How many different possible passwords can be formed by using nine letters? (Assume an upper-case letter is different from a lower-case one) **Answer: 2 779 905 883 635 700**

20. Determine how many 4-digit numbers can be formed using only digits 1, 2, 3 that are odd and less than 2000. **Answer: 18**
21. Until 1995, the rules for three-digit area code were:
 -the first digit could not be 0 or 1;
 -the second digit had to be 0 or 1;
 -the third digit had no restrictions.
 How many area codes are possible? **Answer: 160**
22. A binary string is an ordered list of zeroes and ones (for example: 01010010 is a binary string of length 8).
 a) How many unique binary strings of length 12 are there?
 b) How many binary strings of length 12 end in the string 1101?
 c) How many binary strings of length 12 have more than one 0?
23. Suppose I roll three regular six-sided dice: A red die, a blue die, and a green die. Let R be the number shown on the red die, B be the number shown on the blue die, and G be the number shown on the green die. What is the probability that $R + B$ is greater than $B + G$?

Finance

24. John invests \$2000, which earns 6% (simple) interest per year. At the same time, Sarah invests an unknown amount, which earns 8% (simple) interest per year. After one year, both John and Sarah have earned the same amount of interest. How much did Sarah invest?
25. Emma took out a \$2,700 short-term loan to cover her tuition fees. The loan compounds quarterly, meaning interest is added to the balance every three months. After 24 months, Emma checks her account and sees that she now owes \$3,200. Determine the interest rate Emma's lender charged. **Answer: 8.6%**
26. Liam wants to buy a used car in the future and decides to invest \$2,000 in a savings account that earns interest. The bank offers an interest rate of 7.2% per year, compounded monthly. Liam's goal is to let his investment grow until it reaches at least \$4,500 so he can afford a good down payment on the car. How long will it take for his savings to reach his goal? **Answer: 11 years and 4 months**

Transportation

27. Construction of a new road requires a design of 4 kilometres horizontally and a drop of 600 metres in elevation. Determine the slope of the road.
 (A slope of a road is determined as a ratio of horizontal to vertical while keeping the units within the ratio matching) **Answer: 0.15**
28. A messenger delivers certified packages in our province. In delivering a package on Monday, he used his bike (an average speed of 35 km/h) but he was late 2 hours. On Tuesday he needed to deliver another package to the same place and he decided to use his racing bike (average speed 50 km/h), but he was early 1 hour. Determine the distance between the messengers' starting place and the destination for deliver the package. **Answer: 350 k**

Urban Planning

29. A new playground park contains a rectangular green piece with dimensions measuring 6 m x 4 m. The green piece contains 6 shrubs shown on the picture below as tangent circles with their centers spaced 2 m apart. Unit conversion: $1\text{m}^2 = (3.28)^2\text{ft}^2$
- Determine the percentage of the rectangle covered by the circles. **Answer: 78.5%**
 - Determine how much of the ground is not covered by shrubs. Round your answer to the nearest square metre. **Answer: 5m^2**
 - The ground between the shrubs needs to be covered with mulch. One Vigoro Mulch bag covers 12 square feet. How many bags are needed? Round your answer to the nearest integer. **Answer 5 bags**
 - The nearest store sells Vigoro Mulch at a price of \$7.99 per bag. Include the 13% tax on the bill; round your answer to the nearest cent. **Answer: \$ 45.15**

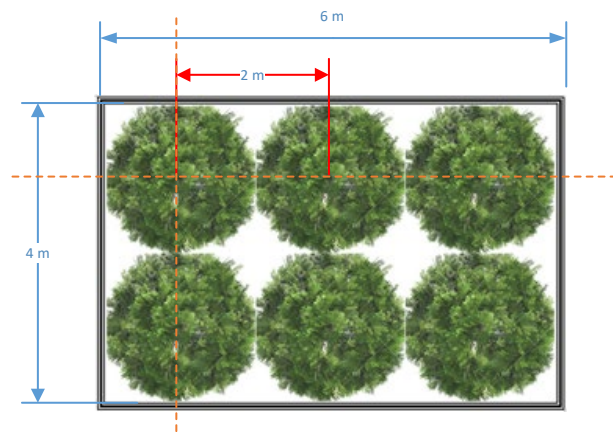

Agriculture

30. Consider a triangular-shaped farmland as shown in figure, where the lengths of the two sides each equal 4 metres more than half of the base side. Additionally, the area of the triangular land is 6 times the length of the base side. To expand the land area, a semicircular portion is appended to the base side of the triangular land. Calculate the total area and perimeter of the land.

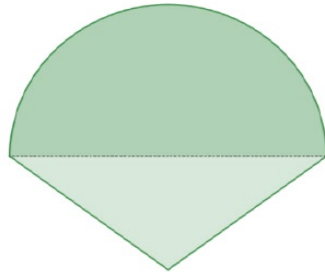

Figure is not to scale

Grade 12

General Interest

1. Ms. Brown is looking to buy a new dishwasher. She is interested in a specific model which can be found in few different stores. Sears has the model listed as \$369.99 but this weekend there is a promotion of \$25.00 cashback. The same dishwasher model can be found in Home Depot with a price of \$395.50 and this week there is a discount of 15% on all appliances. In addition, Canadian tire carries the same model with a price \$344.99 where Ms. Brown can use her credit card and gain 2% in Canadian tire money for future spending needs.
Which store has the best price option for the dishwasher model? Determine the amount Ms. Brown is charged if she purchased the dishwasher in that store. **Answer: Home Depot; \$336.18**
2. Toby and Sylvia are playing a simple game of “winner takes all” involving tossing of a coin. The first player to achieve ten wins is to receive a \$100. However, the game was interrupted when Toby had 7 and Sylvia had 9 wins. Sylvia claimed that, as she needed only one more win to win the whole game, she should receive the \$100. Toby, on the other hand claimed that he could have won the next 4 tosses and he should also receive the \$100. How would they split the \$100?
Answer: Sylvia receives \$90 and Toby receives \$10
3. Anthony is continuing his post-secondary education at Mohawk College. He is taking 5 different courses with different number of hours per week that needs to be taken in consideration when calculating his Grade Point Average (GPA). Determine Anthony’s GPA if after the first term he has received the following grade report:

Math (3 hours)	Communications (2 hours)	Course A (4 hours)	Course B (4 hours)	Course C (3 hours)
100	85	80	92	78

Answer: 87

Mechanical Engineering

4. Mr. Jones needs to measure the volume of a stone with irregular shape. He plans to use a tall cylindrical glass with radius 4.5 cm and a height 25 cm. He pours water in the glass to height of 10 cm. After dropping the stone in this glass, he notices the water height increased to 12.7cm. Determine the volume of the stone, rounded to the nearest whole cubic centimetre.
(*Volume of a cylinder* = $\pi r^2 H$ where r is the radius of the cylinder, $\pi = 3.14$ and H is the height of the cylinder)
Answer: $V_{stone} = 172cm^3$
5. Modern submarines can go to a depth of 730m before they collapse due to pressure. Calculate the pressure experienced by the submarine at that depth if $\gamma_{water} = 9.81 kN/m^3$
(The pressure Δp is calculated by the formula $\Delta p = \gamma \cdot h$, where γ is the specific weight of the fluid, h is the depth from a free surface) (Round your answer to the nearest MN/m^2)
Answer: $\frac{7MN}{m^2} = 7MPa$

6. A missile is launched at an angle of $23^{\circ}50'25''$ with respect to the horizontal plane. It travels in a straight line for 3 min with an average speed of 6255 km/h. Determine the altitude of the missile at this time? **Answer: 126.4 km**

7. Determine the number of cubic centimetres of material contained in the jig bushing shown. (Adapted from Mathematics for Machine Technology by Robert D. Smith)

Answer: 13.180 cm³

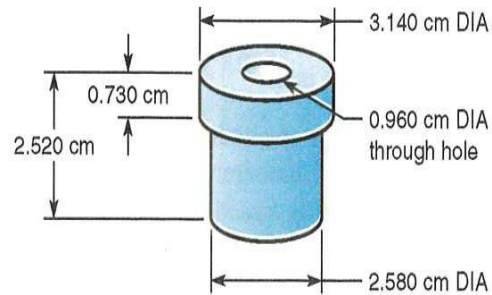

8. An oil storage tank 40 dm long has a flat bottom as shown below.

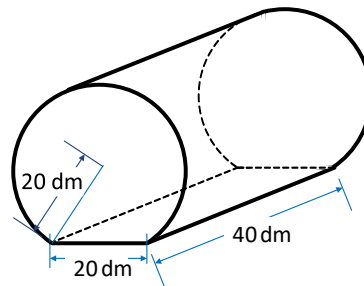

- Determine the area of the flat bottom.
- Determine the area of the part of circle that represents the front side
- What volume of oil will the tank hold?
- Determine the surface area of the oil tank.

Answers:

Civil Engineering

9. Considering heat loss in a building, the building code states that the window area in a building cannot exceed 20% of the total floor area. The new building has a floor area of 175 square metres and the plan suggests 45 square metres of windows. Will this satisfy the building code?

Answer: No, the maximum allowed window area is 35 m².

10. A vertical aerial is positioned on horizontal ground. Ms. Santiago is the new surveyor who is positioned 72 m due west of the aerial and she measures the angle of elevation of the top to be 56° . Mr. Boyle on the other hand is positioned 12 m north of her and he measures the angle of elevation of the top to be 34° . Determine the height of the aerial. **Answer: 58.65 m**

Architecture

11. A designer flag is made out of three different materials with different price for the new City Hall in town. Based on the sketch below calculate the total cost of producing one flag (including 13% tax). (Round to the nearest dollar) **Answer: \$14 490**

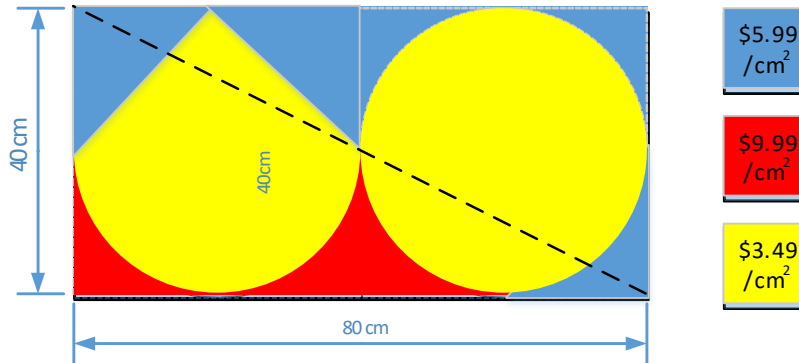

12. A famous sculptor has created his new masterpiece in a form of a square pyramid inscribed in a sphere which centre divides the height of the pyramid into two parts of length 4 cm and 5 cm. Determine the volume of the sphere.

Answer: 54 cm³

Biotechnology

13. In order to determine the number of a certain type of white blood cells per cubic millimetre, a lab technician needs to count the number of these cells in a specific area under a microscope and then multiply by an area factor of 5.5. If the technician counted 92 white blood cells in the designated area determine the count per cubic millimetre. **Answer: 506 of the certain type white blood cells.**
14. A biologist is asked to determine the growth rate of a certain type of bacteria. He is given one hundred bacteria in a favorable growth medium. After 8 hours the biologist counts 850 bacteria. Assuming exponential growth, determine the growth constant "k" for the bacteria? (Hint: use $A = Ce^{kt}$) **Answer: 0.2675**
15. A certain type of bacteria growing in a container doubles every 8 minutes. A biologist started with 1 bacterium and assuming the container has the favourable growth medium how many bacteria could be present at the end of one hour? (Hint: use $A = Ce^{kt}$) **Answer: 65**

Computer Science

16. Determine how many 2-digit numbers can be formed using digits 0–9. **Answer: 90**
17. How many different possible passwords can be formed by using nine letters? (Assume an upper-case letter is different from a lower-case one) **Answer: 2 779 905 883 635 700**
18. Determine how many 4-digit numbers can be formed using only digits 1, 2, 3 that are odd and less than 2000. **Answer: 18**

19. Until 1995, the rules for three-digit area code were:

- the first digit could not be 0 or 1;
- the second digit had to be 0 or 1;
- the third digit had no restrictions.

How many area codes are possible?

Answer: 160

Electrical Engineering

20. An electrical resistor is rated at 500 ohms plus or minus 3%. Determine the range of resistance.

Answer: 485 ohms to 515 ohms

21. A box of 100 semiconductor chips contains 30 chips that are defective. We select at random, without replacement, from the box

- a. Determine the probability that the first one selected is defective.
- b. Determine the probability that the first defective is the 5th one chosen.
- c. Determine the probability that the second one selected is defective given that the first one was defective.
- d. Determine the probability that the first 2 chosen are defective.
- e. Determine the probability the first 5 selected are defective.
- f. How does the answer to parts (a) - (e) change if chips selected were replaced prior to the next selection?

Answer: a) 30%; b) 7.3%; c) 29%; d) 8.8%; e) 0.19%; f) (a) same; (b) 7.2%; (c) 30% (d) 9% (e) 0.24%

22. The total resistance (R_T) of a circuit consisting of two parallel resistors with resistance R_1 and R_2 is given by the formula.

$$\frac{1}{R_T} = \frac{1}{R_1} + \frac{1}{R_2}$$

What is the value of R_1 , given that $R_2 = 2\Omega$ and the total resistance is $R_T = 1.5\Omega$?

Environmental Science

23. The local environmental agency, monitoring pollution levels in a nearby lake, observes a decrease in pollutant concentration from 85 g/L to 75 g/L within a week due to filtration processes.

- a) Determine the pollutant level in the lake after 4 weeks.
- b) A new pollution source introduced in Week 3 increases the concentration by 10%, what will be the concentration 4 weeks after its introduction?
- c) How long will it take for the concentration to reduce to 10 g/L after the introduction of the new source?

Finance

24. Sophia wants to start an emergency fund to cover unexpected expenses like medical bills or car repairs. She deposits \$1,000 into a savings account that earns interest at an annual rate of 4.25%, compounded daily. She is curious to know how much interest she will earn:

- a) during the first year? (Answer: \$43.41)
- b) during the second year? (Answer: \$45.30)

25. Emma's parents want to start saving for her future education. When she is born, they deposit \$1000 into a special savings account that earns 12% interest per year, compounded monthly. They decide not to make any additional deposits and just let the money grow over time. How much money will be in the account when Emma turns 18? (Answer: \$8578.61)